





















**Model**

**2475**

**Description**

“A frame” triple section  
bottom loading arm

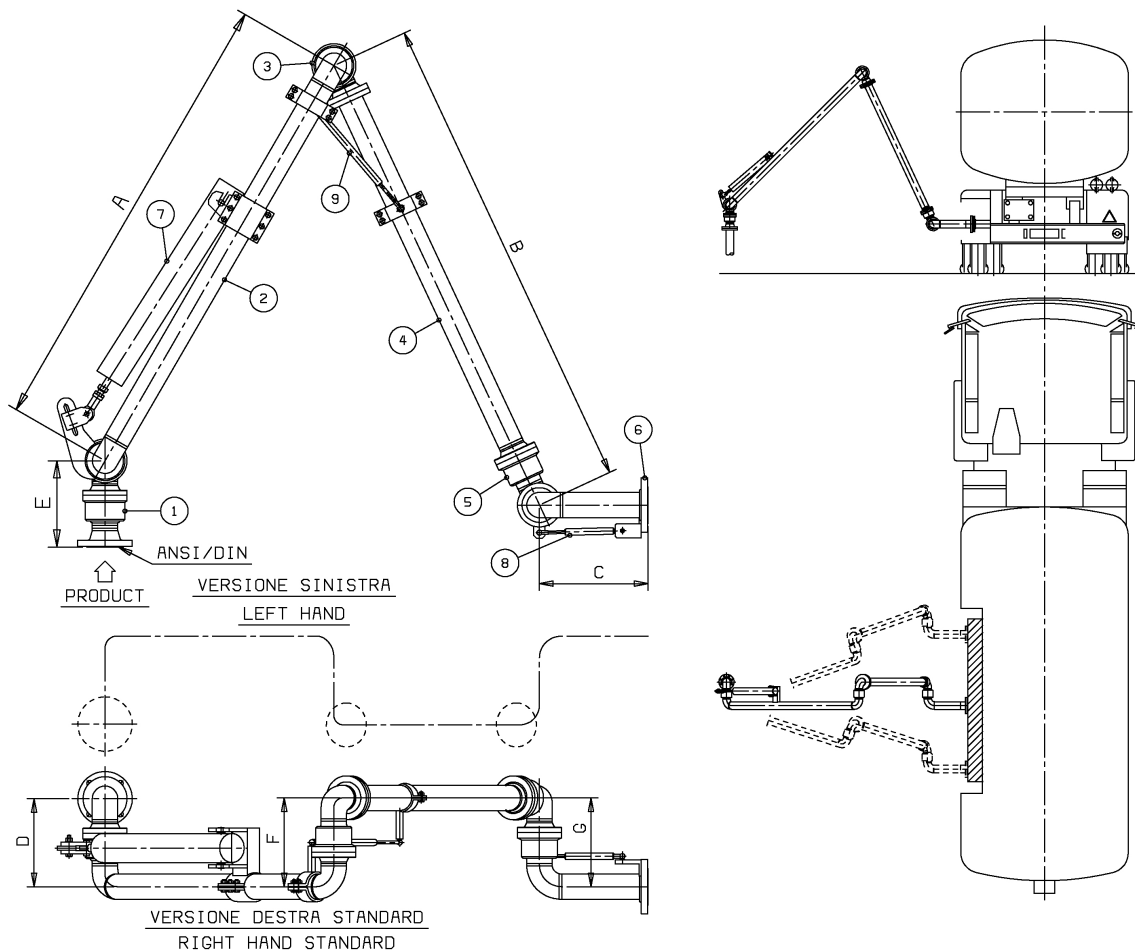

Operating conditions	
Design pressure	10.0 Bar G
Test pressure	15.0 Bar G
Design temperature	-15°C / +65°C
Seal material	PTFE
Flow rate	3"–75 mc/h Max 4"–125 mc/h Max

N.	Description	Dwg/Mod
1	Style 50 double swing joint	2815
2	Inboard pipe	
3	Style 40 swivel joint	2815
4	Outboard pipe	
5	Style 50 double swing joint	2815
6	Coupler flange connection	
7	Spring balancing cylinder	05182
8	Gas spring balancer	
9	Gas spring balancer	

Standard dimensions		
Dn.	3"	4"
A	1500/2800	1500/2800
B	1500/2800	1500/2800
C	600	600
D	309	373
E	303	348
F	309	373
G	309	373
Weight	130	160